



Z86116

CMOS Z8[®] PN MODULATOR WIRELESS CONTROLLER

FEATURES

Part	ROM (Kbytes)	RAM* (Kbytes)	SPEED (MHz)
Z86116	1	124	12

* General-Purpose

- 18-Pin DIP and SOIC Packages
- 3.0- to 5.5-Volt Operating Range
- Low-Power Consumption
- 0° to +70°C Temperature Range
- Expanded Register File (ERF)

- On-Chip PN Modulator for Spread Spectrum Communications
- 12 Input/Output Lines (One with Comparator Input)
- Vectored, Prioritized Interrupts With Programmable Polarity
- Analog Comparator
- Two Programmable 8-Bit Counter/Timers Each with Two 6-Bit Programmable Prescalers
- Watch-Dog Timer (WDT)/Power-On Reset (POR)
- On-Chip Oscillator that Accepts a RC, or External Clock Drive
- Low-Voltage Protection / Low-EMI Option

GENERAL DESCRIPTION

The Z86116 Wireless Controller is a member of the Z8[®] single-chip microcontroller family based on Zilog's 8-bit microcontroller core. The Z86116 is designed with specific features for wireless spread spectrum applications using direct sequence pseudo-noise (PN) modulation.

Three address spaces, the Program Memory, Register File, and Expanded Register File (ERF), support a wide range of memory configurations. Through the ERF, the designer has access to three additional control registers that provide extra peripheral devices, I/O ports, and register addresses.

For applications demanding powerful I/O capabilities, the Z86116's dedicated input and output lines are grouped into two ports, and are configurable under software control to provide timing, status signals, or parallel I/O.

Notes:

All Signals with a preceding front slash, "/", are active Low, e.g., B//W (WORD is active Low); /B/W (BYTE is active Low, only).

Power connections follow conventional descriptions below:

Connection	Circuit	Device
Power Ground	V _{CC} GND	V _{DD} V _{SS}

FUNCTIONAL DESCRIPTION

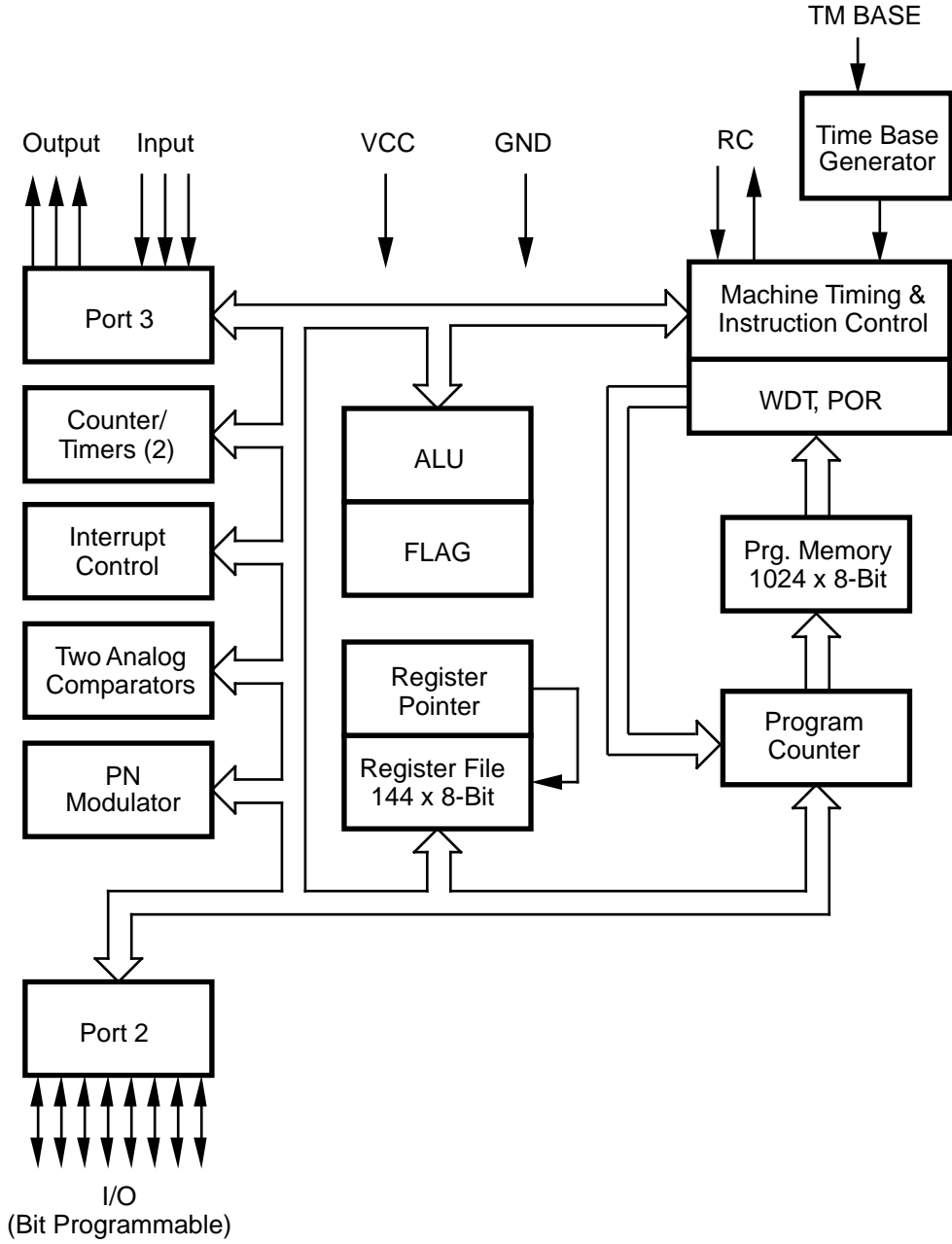

Functional Block Diagram

FUNCTIONAL DESCRIPTION (Continued)

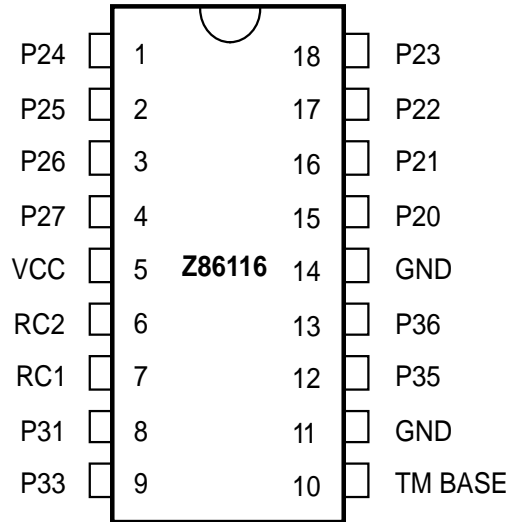

18-Pin DIP/SOIC Pin Configuration

18-Pin DIP/SOIC Pin Identification

No	Symbol	Function	Direction
1-4	P24-27	Port 2, Pins 4, 5, 6, 7	In/Output
5	V _{CC}	Power Supply	Input
6	RC2	RC Oscillator Clock	Output
7	RC1	RC Oscillator Clock	Input
8-9	P31, P33	Port 3, Pins 1, 3	Fixed Input
10	TM BASE	Time Base Clock	Input
11	GND	Ground	
12-13	P35-36	Port 3, Pins 5, 6	Fixed Output
14	GND	Ground	
15-18	P20-23	Port 2, Pins 0, 1, 2, 3	In/Output

ABSOLUTE MAXIMUM RATINGS

Symbol	Description	Min	Max	Units
V_{CC}	Supply Voltage*	-0.3	+7.0	V
T_{STG}	Storage Temp	-65	+150	C
T_A	Oper Ambient Temp	†		C

Notes:

* Voltage on all pins with respect to GND.

† See Ordering Information

Stresses greater than those listed under Absolute Maximum Ratings may cause permanent damage to the device. This is a stress rating only; operation of the device at any condition above those indicated in the operational sections of these specifications is not implied. Exposure to absolute maximum rating conditions for extended period may affect device reliability.

STANDARD TEST CONDITIONS

The characteristics listed below apply for standard test conditions as noted. All voltages are referenced to ground. Positive current flows into the referenced pin (Test Load Configuration).

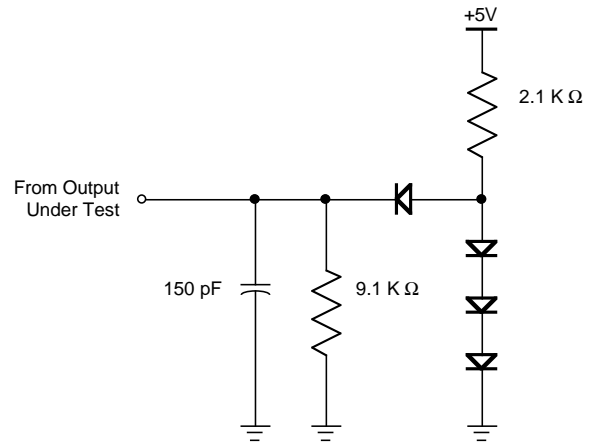

Test Load Configuration

DC ELECTRICAL CHARACTERISTICS

Sym	Parameter	V _{CC}	T _A = 0°C to +70°C		Typical @ 25°C	Units	Conditions	Notes
			Min	Max				
	Max Input Voltage	3.0V		12		V	I _{IN} ≤ 250 μA	
		5.5V		12		V	I _{IN} ≤ 250 μA	
V _{CH}	Clock Input High Voltage	3.0V	0.9 V _{CC}	V _{CC} +0.3	2.4	V	Driven by External Clock Generator	
		5.5V	0.9 V _{CC}	V _{CC} +0.3	3.9	V	Driven by External Clock Generator	
V _{CL}	Clock Input Low Voltage	3.0V	V _{SS} -0.3	0.2 V _{CC}	1.6	V	Driven by External Clock Generator	
		5.5V	V _{SS} -0.3	0.2 V _{CC}	2.7	V	Driven by External Clock Generator	
V _{IH}	Input High Voltage	3.0V	0.7 V _{CC}	V _{CC} +0.3	1.8	V		
		5.5V	0.7 V _{CC}	V _{CC} +0.3	2.8	V		
V _{IL}	Input Low Voltage	3.0V	V _{SS} -0.3	0.2 V _{CC}	1.0	V		
		5.5V	V _{SS} -0.3	0.2 V _{CC}	1.5	V		
V _{OH}	Output High Voltage	3.0V	V _{CC} -0.4		3.1	V	I _{OH} = -2.0 mA	
		5.5V	V _{CC} -0.4		4.8	V	I _{OH} = -2.0 mA	
V _{OL1}	Output Low Voltage	3.0V		0.8	0.2	V	I _{OL} = +4.0 mA	
		5.5V		0.4	0.1	V	I _{OL} = +4.0 mA	
V _{OL2}	Output Low Voltage	3.0V		1.0	0.4	V	I _{OL} = 6 mA, 3 Pin Max	
		5.5V		1.0	0.5	V	I _{OL} = +12 mA, 3 Pin Max	
V _{OFFSET}	Comparator Input Offset Voltage	3.0V		25	10	mV		
		5.5V		25	10	mV		
I _{IL}	Input Leakage (Input bias current of comparator)	3.0V	-1.0	1.0		μA	V _{IN} = 0V, V _{CC}	
		5.5V	-1.0	1.0		μA	V _{IN} = 0V, V _{CC}	
I _{OL}	Output Leakage	3.0V	-1.0	1.0		μA	V _{IN} = 0V, V _{CC}	
		5.5V	-1.0	1.0		μA	V _{IN} = 0V, V _{CC}	
I _{CC}	Supply Current	3.0V		8.0	4.5	mA	@ 12 MHz	[2,3]
		5.5V		15	9.0	mA	@ 12 MHz	[2,3]
		4.5V		15	10	μA	10 kHz; External RC	[2,5]

DC ELECTRICAL CHARACTERISTICS (Continued)

Sym	Parameter	V _{CC}	T _A = 0°C to +70°C		Typical @ 25°C	Units	Conditions	Notes
			Min	Max				
I _{CC1}	Standby Current (HALT Mode)	3.0V		4.5	2.0	mA	HALT mode V _{IN} = 0V, V _{CC} @ 12 MHz	[2,3]
		5.5V		7.0	4.0	mA	HALT mode V _{IN} = 0V, V _{CC} @ 12 MHz	[2,3]
		3.0V		2.0	1.0	mA	Clock Divide-by-16 @ 12 MHz	[2,3]
		5.5V		4.5	2.5	mA	Clock Divide-by-16 @ 12 MHz	[2,3]
I _{CC2}	Standby Current (STOP Mode)	3.0V		10	1.0	μA	STOP mode V _{IN} = 0V, V _{CC} WDT is not Running	[4]
		5.5V		10	3.0	μA	STOP mode V _{IN} = 0V, V _{CC} WDT is not Running	[4]
		3.0V		TBD		μA	STOP mode V _{IN} = 0V, V _{CC} WDT is Running	[4]
		5.5V		TBD	200	μA	STOP mode V _{IN} = 0V, V _{CC} WDT is Running	[4]
		5.5V		12	5	μA	STOP Mode; TM BASE = 32.768 KHz; WDT is not Running	[6]
T _{POR}	Power-On Reset	3.0V	7	24	13	ms		
		5.5V	3	13	7	ms		
V _{BO}	V _{CC} Low Voltage Protection Voltage		1.50	2.65	2.1	V	2 MHz max Ext. CLK Freq.	[1]

Notes

- [1] V_{LV} increases as the temperature decreases.
- [2] All outputs unloaded, I/O pins floating,
inputs at either rail, TM BASE clock input grounded.
- [3] C_{L1} = C_{L2} = 100 pF.
- [4] Same as note [2] except inputs at V_{CC}.
- [5] Low EMI oscillator selected;
SCLK = RC/2
RC selected for WDT;
10 kHz RC Oscillator
(corresponding to R ≈ 1.2 MΩ, C ≈ 68 pF).
- [6] Z8 in STOP mode;
WDT off;
TM BASE selected as Z8 system clock source
Time base counter enabled;
V_{CC} = 5.5V.

AC ELECTRICAL CHARACTERISTICS

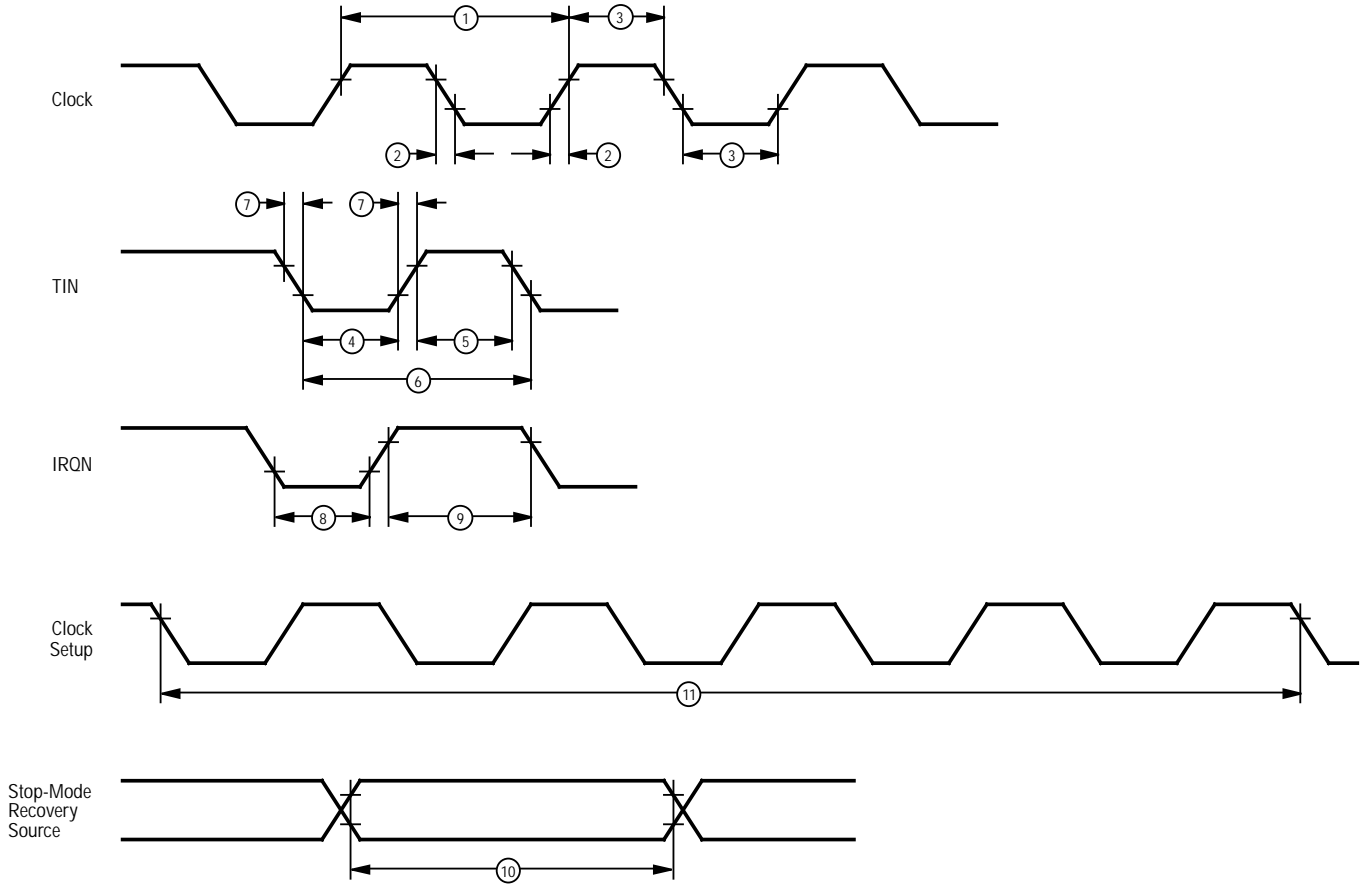

AC ELECTRICAL CHARACTERISTICS (Continued)

No	Sym	Parameter	V _{CC} Note [3]	T _A = 0°C to +70°C 12 MHz		Units	Notes
				Min	Max		
1	TpC	Input Clock Period	3.3V	83	100,000	ns	[1]
			5.0V	83	100,000	ns	[1]
2	TrC,TfC	Clock Input Rise and Fall Times	3.3V		15	ns	[1]
			5.0V		15	ns	[1]
3	TwC	Input Clock Width	3.3V	26		ns	[1]
			5.0V	26		ns	[1]
4	TwTinL	Timer Input Low Width	3.3V	100		ns	[1]
			5.0V	70		ns	[1]
5	TwTinH	Timer Input High Width	3.3V	3TpC			[1]
6	TpTin	Timer Input Period	5.0V	3TpC			[1]
			3.3V	8TpC			[1]
			5.0V	8TpC			[1]
7	TrTin, TtTin	Timer Input Rise and Fall Timer	3.3V		100	ns	[1]
			5.0V		100	ns	[1]
8	TwlL	Int. Request Input Low Time	3.3V	100		ns	[1,2]
			5.0V	70		ns	[1,2]
9	TwhH	Int. Request Input High Time	3.3V	3TpC			[1,2]
			5.0V	3TpC			[1,2]
10	TwsM	Stop-Mode Recovery Width Spec	3.3V	12		ns	
			5.0V	12		ns	
11	Tost	Oscillator Startup Time	3.3V		5TpC		Reg.[4]
			5.0V		5TpC	ns	
	Twdt	Watch-Dog Timer Refresh Time	3.3V	15			[5]
			5.0V	5		ms	D0 = 0 [6, D1 = 0 [6]
			3.3V	30		ms	D0 = 1 [6]
			5.0V	16		ms	D1 = 0 [6]
			3.3V	60		ms	D0 = 0 [6]
			5.0V	25		ms	D1 = 1 [6]
			3.3V	250		ms	D0 = 1 [6]
5.0V	120		ms	D1 = 1 [6]			

Notes:

- [1] Timing Reference uses 0.9 V_{CC} for a logic 1 and 0.1 V_{CC} for a logic 0.
- [2] Interrupt request through Port 3 (P33-P31).
- [3] 5.0V ±0.5V, 3.3V ±0.3V.
- [4] SMR-D5 = 0.
- [5] Reg. WDTMR.
- [6] WDT Oscillator only.

Pre-Characterization Product:

The product represented by this CPS is newly introduced and Zilog has not completed the full characterization of the product. The CPS states what Zilog knows about this product at this time, but additional features or non-con-

formance with some aspects of the CPS may be found, either by Zilog or its customers in the course of further application and characterization work. In addition, Zilog cautions that delivery may be uncertain at times, due to start-up yield issues.

© 1995 by Zilog, Inc. All rights reserved. No part of this document may be copied or reproduced in any form or by any means without the prior written consent of Zilog, Inc. The information in this document is subject to change without notice. Devices sold by Zilog, Inc. are covered by warranty and patent indemnification provisions appearing in Zilog, Inc. Terms and Conditions of Sale only. Zilog, Inc. makes no warranty, express, statutory, implied or by description, regarding the information set forth herein or regarding the freedom of the described devices from intellectual property infringement. Zilog, Inc. makes no warranty of merchantability or fitness for any purpose. Zilog, Inc. shall not be responsible for any errors that may appear in this document. Zilog, Inc. makes no commitment to update or keep current the information contained in this document.

Zilog's products are not authorized for use as critical components in life support devices or systems unless a specific written agreement pertaining to such intended use is executed between the customer and Zilog prior to use. Life support devices or systems are those which are intended for surgical implantation into the body, or which sustains life whose failure to perform, when properly used in accordance with instructions for use provided in the labeling, can be reasonably expected to result in significant injury to the user.

Zilog, Inc. 210 East Hacienda Ave.
Campbell, CA 95008-6600
Telephone (408) 370-8000
Telex 910-338-7621
FAX 408 370-8056
Internet: <http://www.zilog.com>